

Agile Product Development

Beyond software: learning from the Agile movement

John S. Farnbach
Principal, Silver Streak Partners LLC
john@silverstreakpartners.com

The Orthodoxy of the Plan

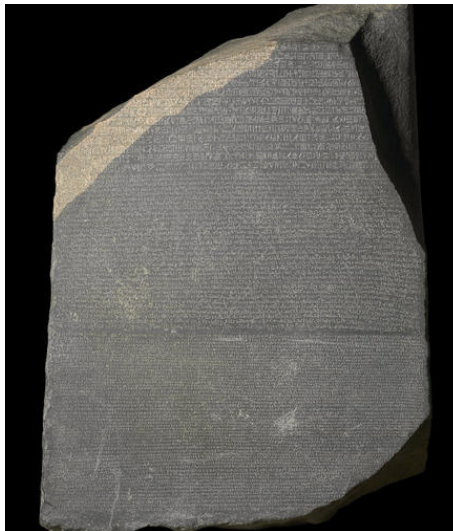

The New Reality

Basis for competition

Operational
Prowess



Innovation
& Dexterity

NPD Processes

Cost efficiency
Predictability



Flexibility
Learning

Agile Product Development

IS:

- ◆ Developing hardware flexibly
- ◆ Mid stream adapting and learning

Smith Flexible
Product Development

Reinertsen Lean

IS NOT:

- ◆ Developing flexible hardware
- ◆ Scalable process

Stage Gate Lite

Cost-focused Lean

Toyota

Goldratt TOC

Flexible Plans & Processes

Fallacy of frozen plans
Delaying decisions

Cost of Change

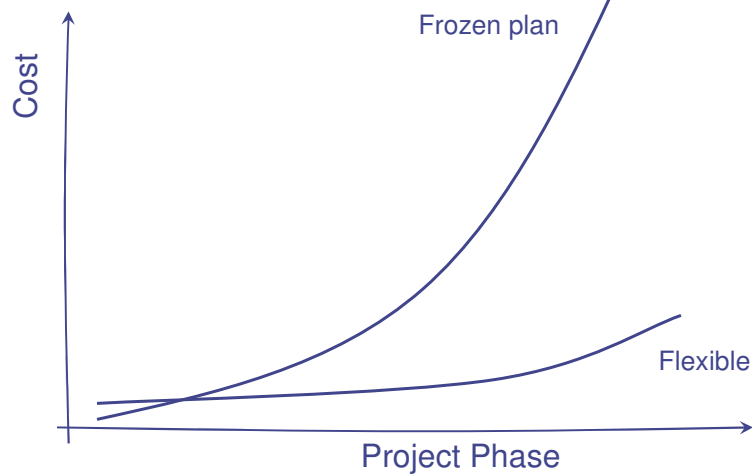

Frozen Plans

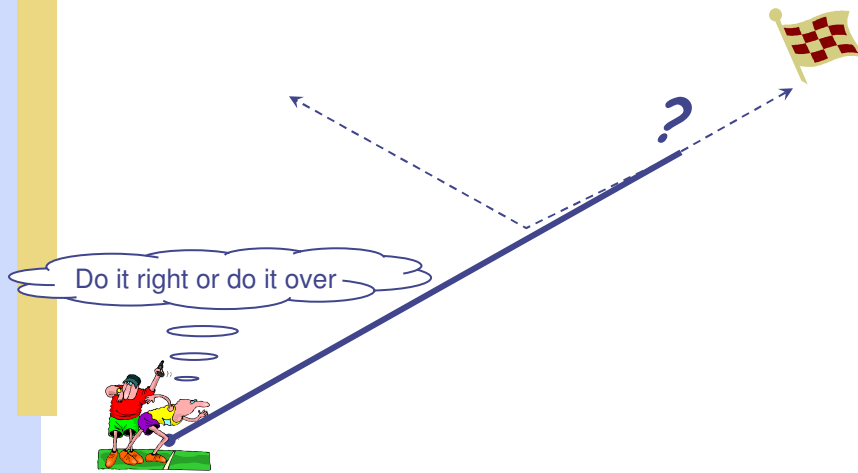

Silver Streak Partners LLC
© 2011 all rights reserved

7

Flexible Planning

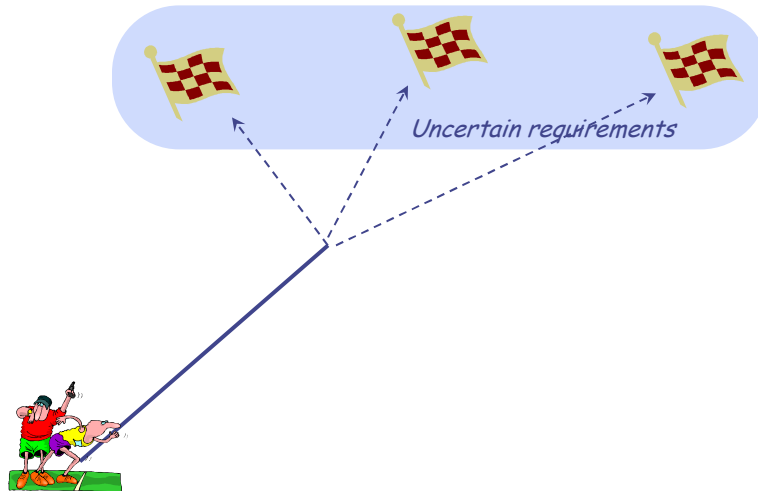

Silver Streak Partners LLC
© 2011 all rights reserved

8

Flexible Processes

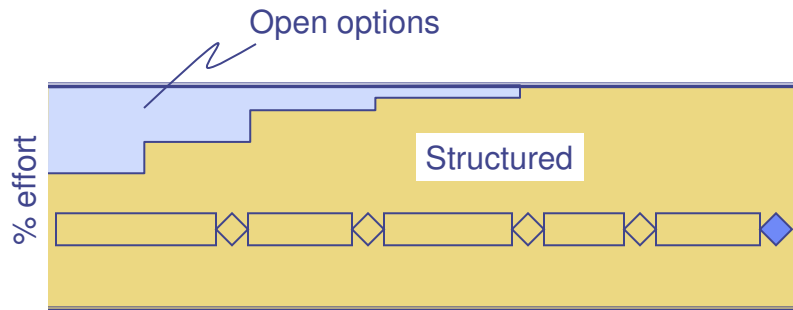

Silver Streak Partners LLC
© 2011 all rights reserved

9

Reducing Cost of Change

Timely decisions
Accelerate learning
Get fast feedback
Fence off changes

© 2011 Silver Streak Partners LLC all rights reserved

10

Timely Decisions

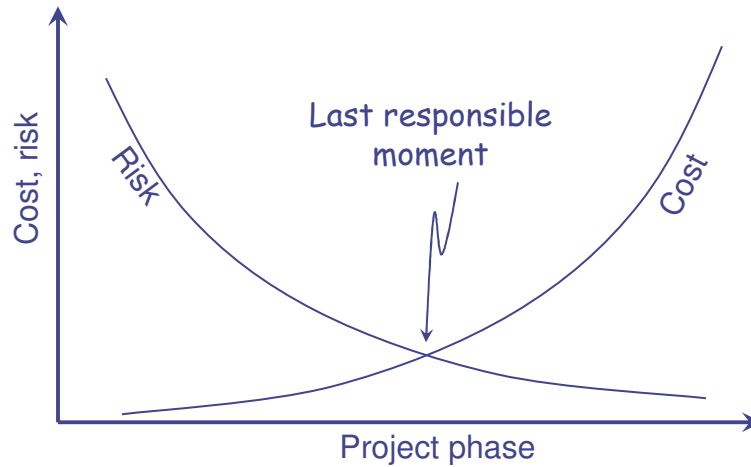

Accelerate Learning

- ◆ Experiments and prototypes
- ◆ Learning, not validation
 - “Failure” is success
- ◆ Many, not few
 - Front-loaded
 - Focused and cheap

Get Fast Feedback

- ◆ Be proactive
- ◆ Customer opinions
- ◆ Standards, technical forums

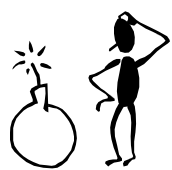

Seek disconfirming information

Fence Off Changes

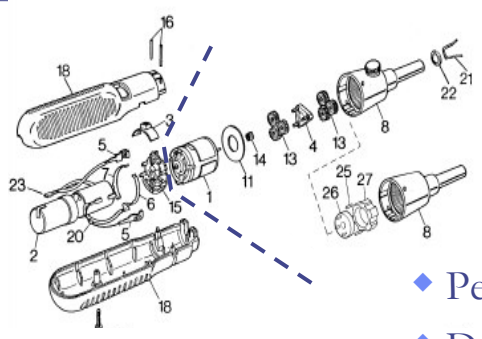

- ◆ Performance, cost, etc.
- ◆ Design flexibility
 - Limit “ripple effect”
 - Align w/org. boundaries

Flexible Teams

Team skills
Communication

Team Skills

Performance Impact

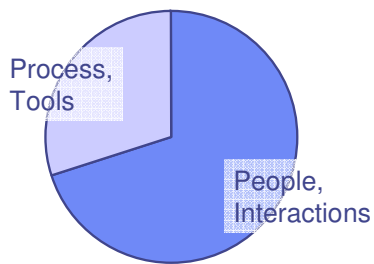

Process Mastery
1 2 3

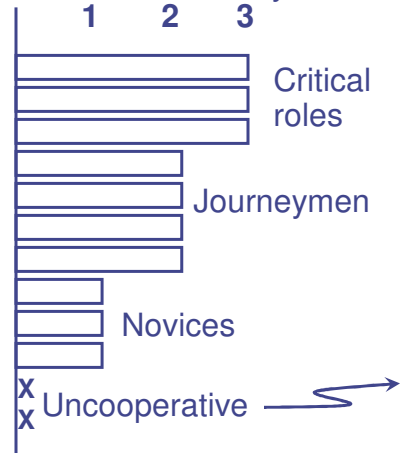

Communication

- ◆ Co-located – 30 ft.
- ◆ Social skills – respect & support
- ◆ Fluid communications – daily (?) stand-ups
- ◆ Dedicated people – full time
- ◆ Generalists – multiple roles

- ◆ Partially co-located?

- Focus on communication processes
- Email, file sharing not sufficient!
- In-person meetings: planning, kickoff, status
- Frequent virtual meetings



Agile Product Development

Beyond software: learning from the Agile movement

Question the orthodoxy of the plan

Plan for uncertainty

Cut the cost of change

Build flexible teams

Presentation copies? john@silverstreakpartners.com