

Dynamic Resource Management

Predictable Projects in an Unpredictable World



John Farnbach
Silver Streak Partners LLC
john@silverstreakpartners.com

The Orthodoxy of the Plan

Plan your work and
Work your plan

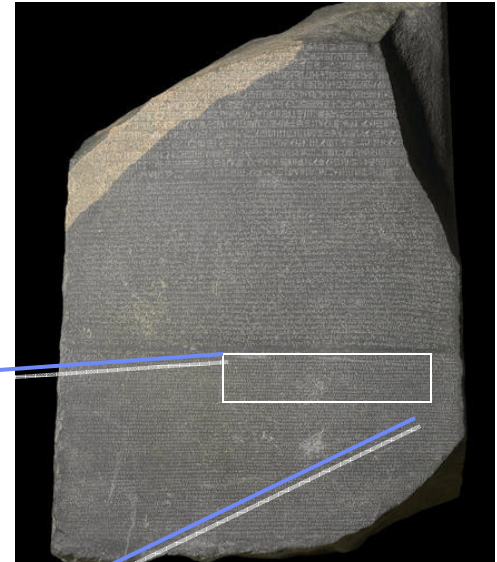

Deterministic Planning

- ◆ Orchestrates task interactions well...

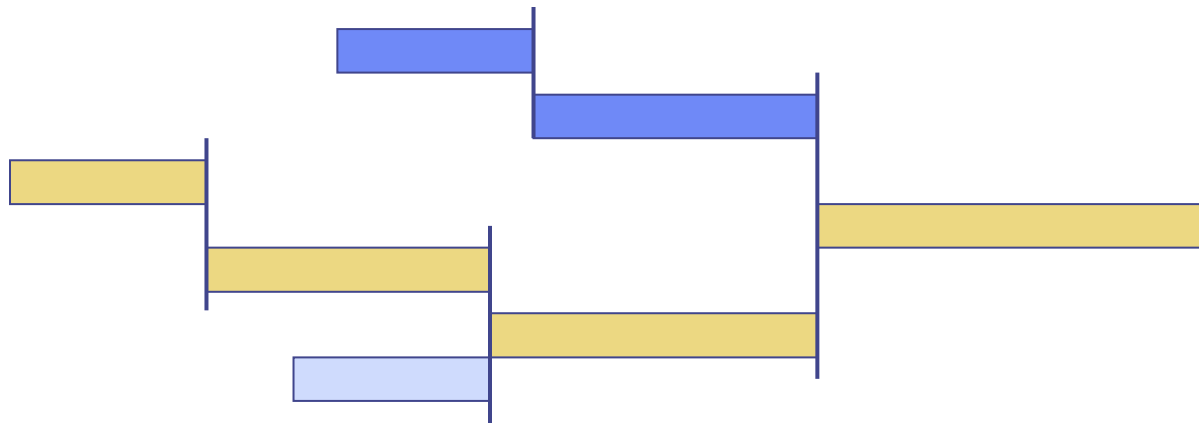

- ◆ ... But planning can't eliminate *variance*.

Cost of Predictability

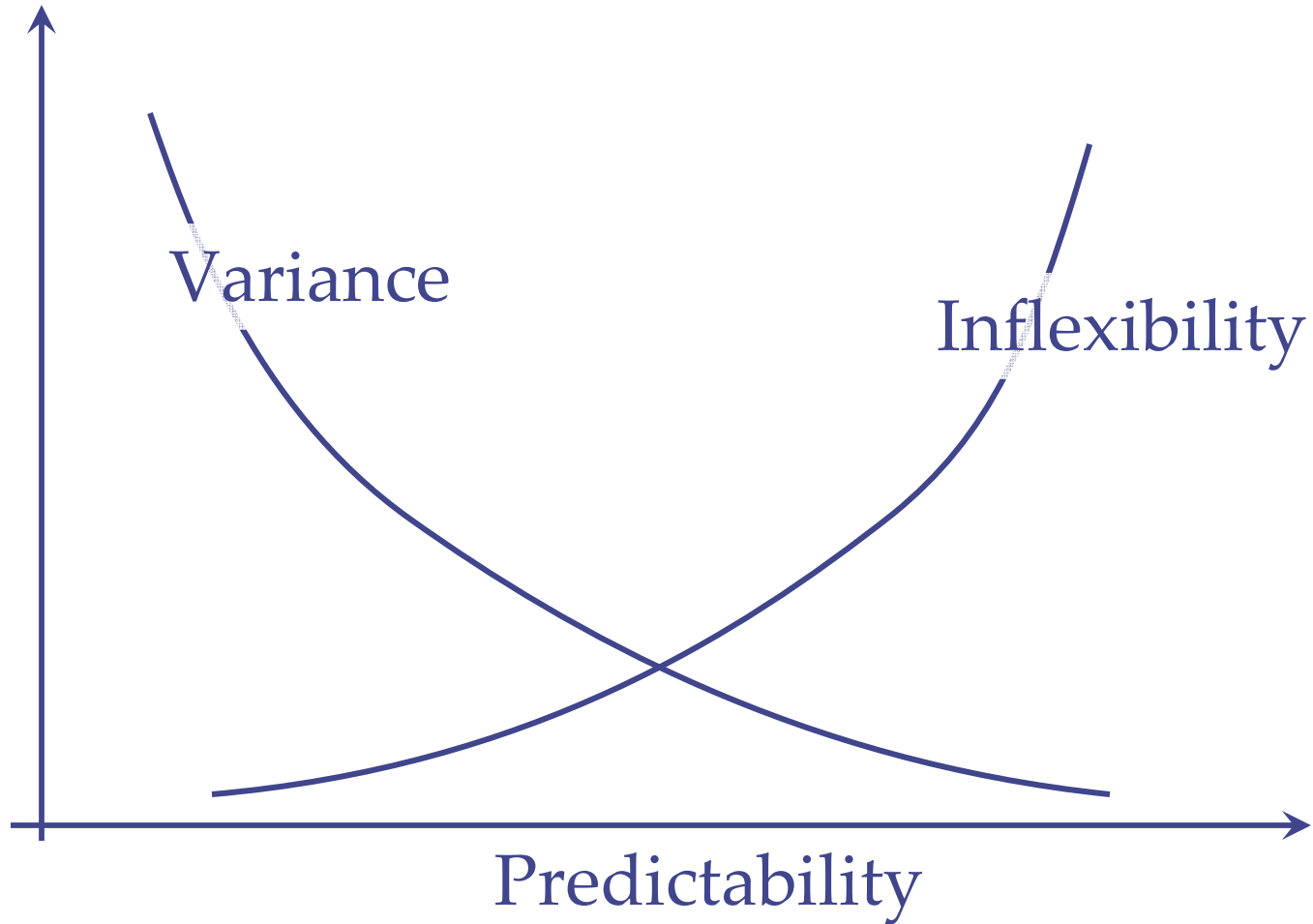

Variance

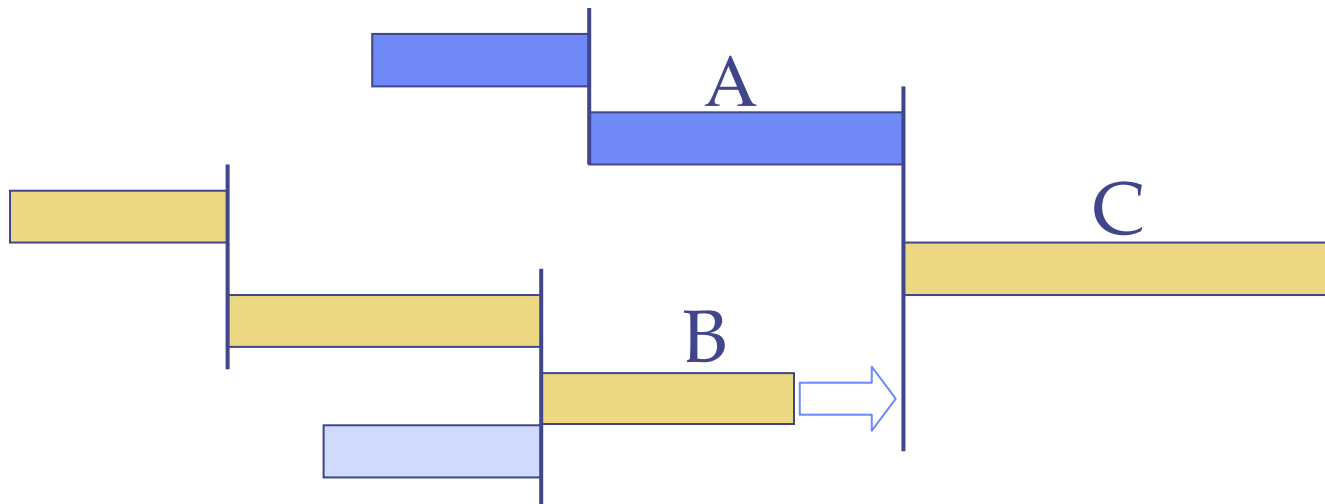



Deterministic planning doesn't work
in an unpredictable world.

Wait a Minute!!

Shorter and more dependable??

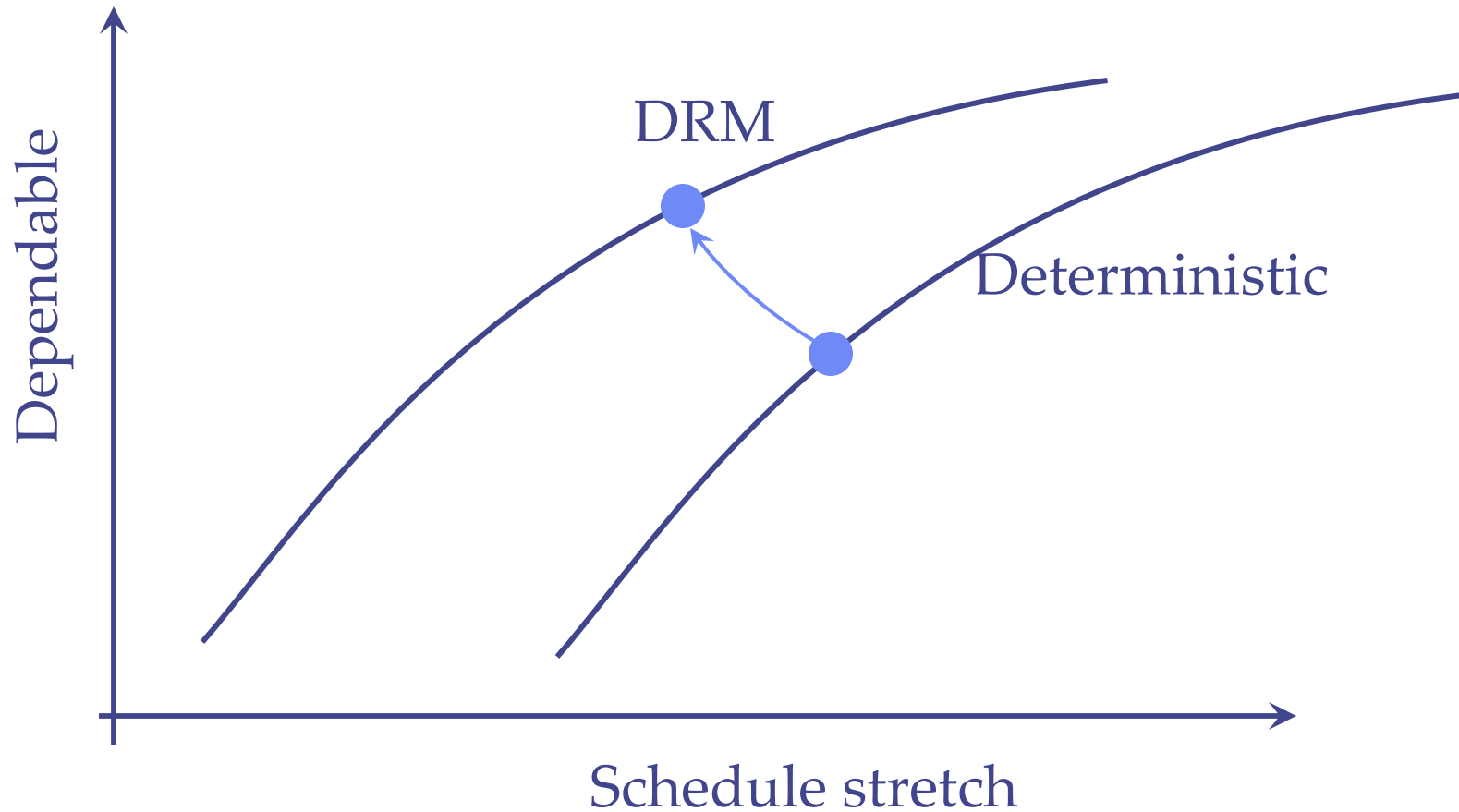

Dynamic Resource Mangement

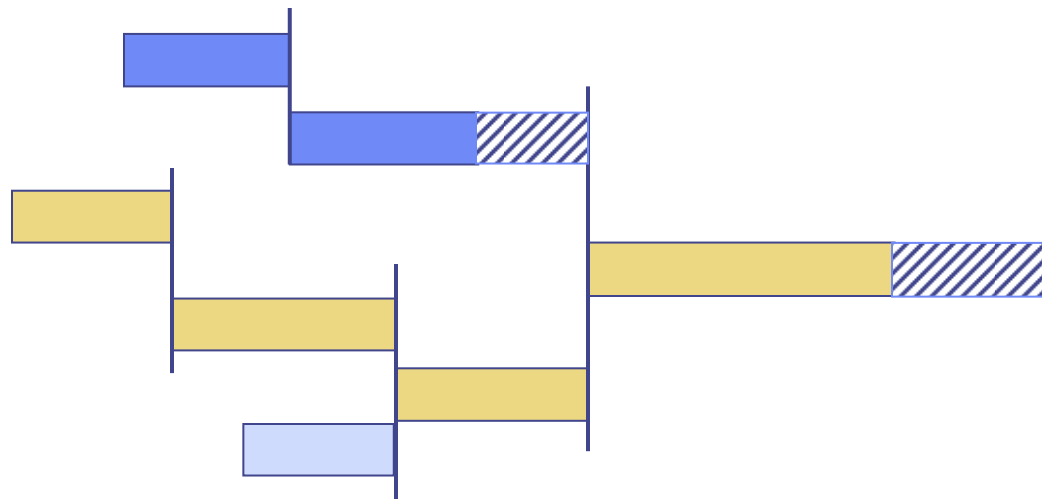

Explicit schedule buffers

Project Management

- ◆ Tasks: reasonable best case
 - All will not complete on time
- ◆ Buffers: critical resource
- ◆ Track buffer consumption

Strive to save buffers, but use when needed

Resource Tracking

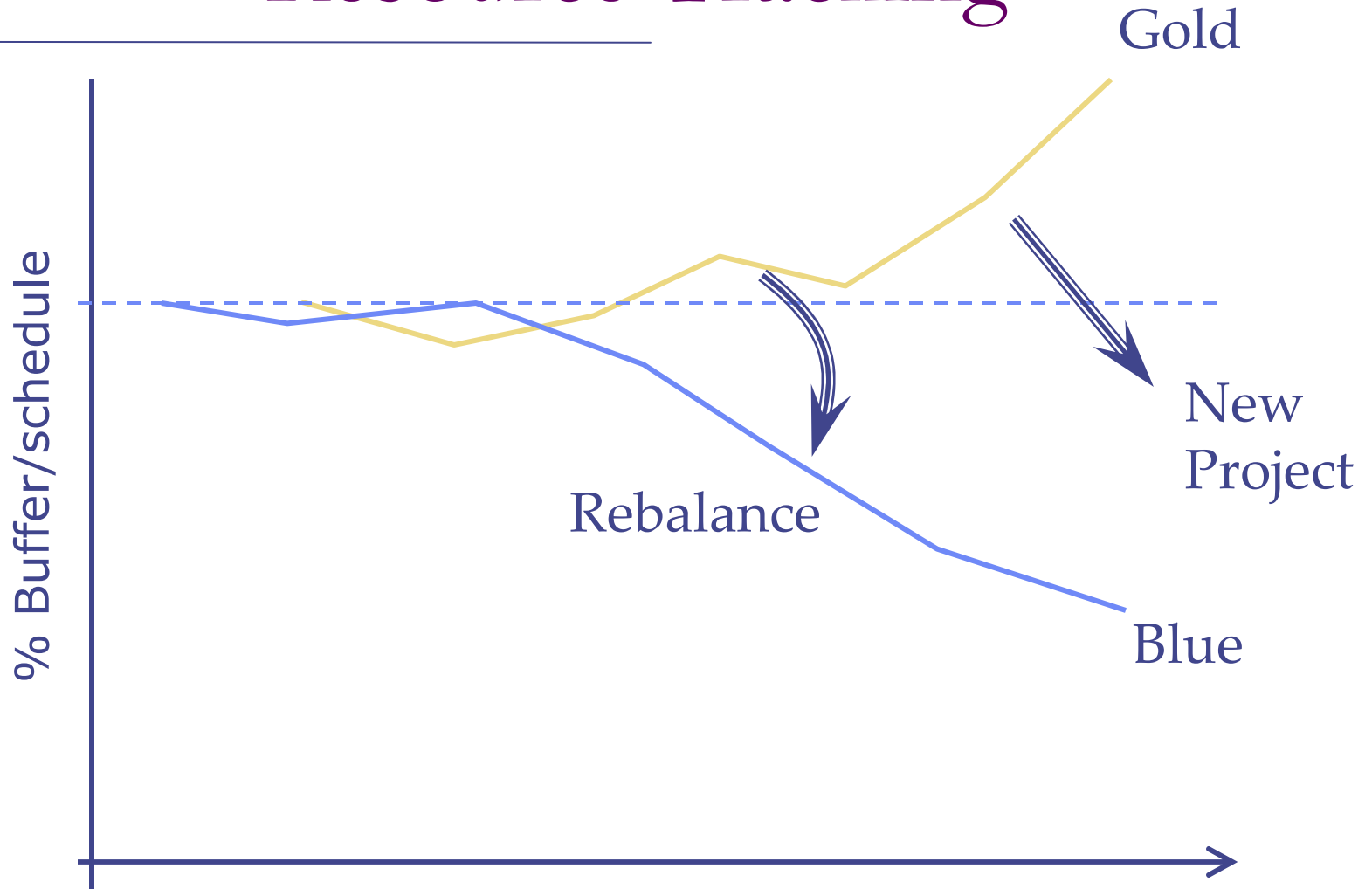

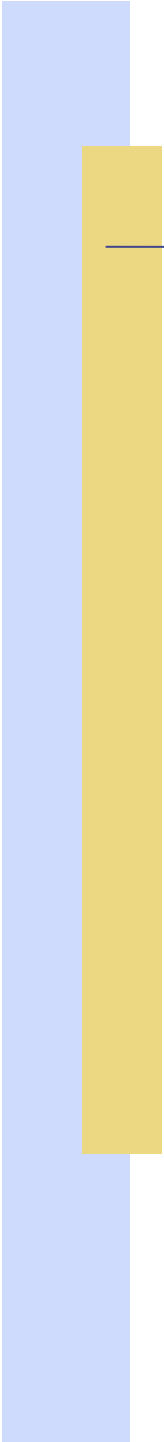

DRM makes schedules shorter and more predictable.

How do you plan a DRM project?

Measurable Tasks

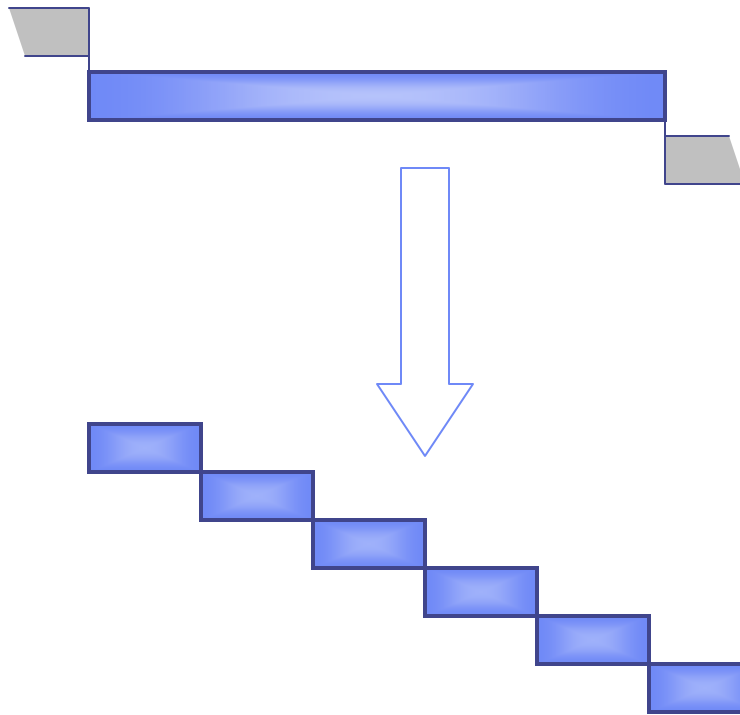

- ◆ Underestimate effort
- ◆ Status biased by hope

- ◆ Realistic estimates
- ◆ Unbiased status

Placing Buffers

- ◆ Fewer is better
 - Statistical aggregation
 - Less confusion
- ◆ Multiple buffers?
 - Buffer external deliverables
 - Specific risks

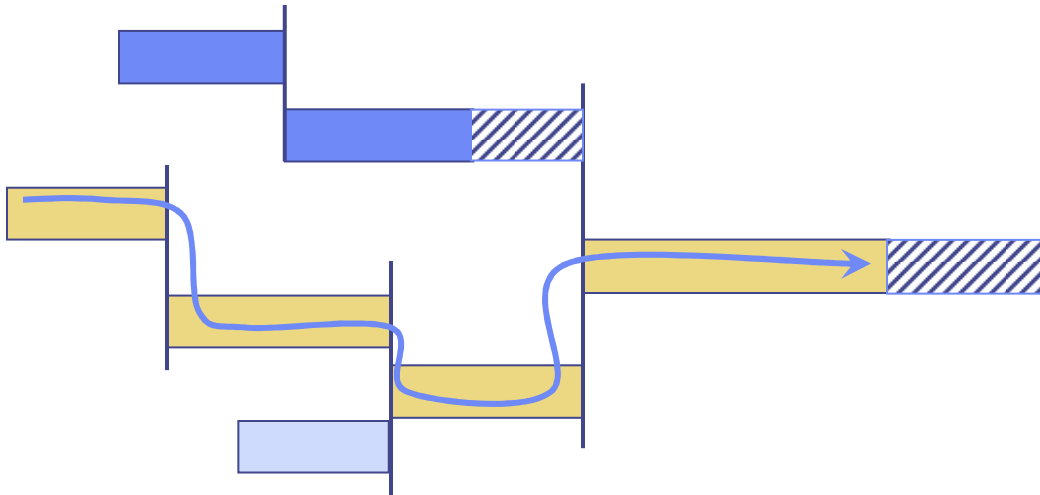

Sizing Buffers

- ◆ Project & planning
 - Technical risk
 - Planning variance



- ◆ Resource management
 - Project priority
 - Business forecast



DRM takes careful attention to planning

What are the problems?

Multi-Tasking

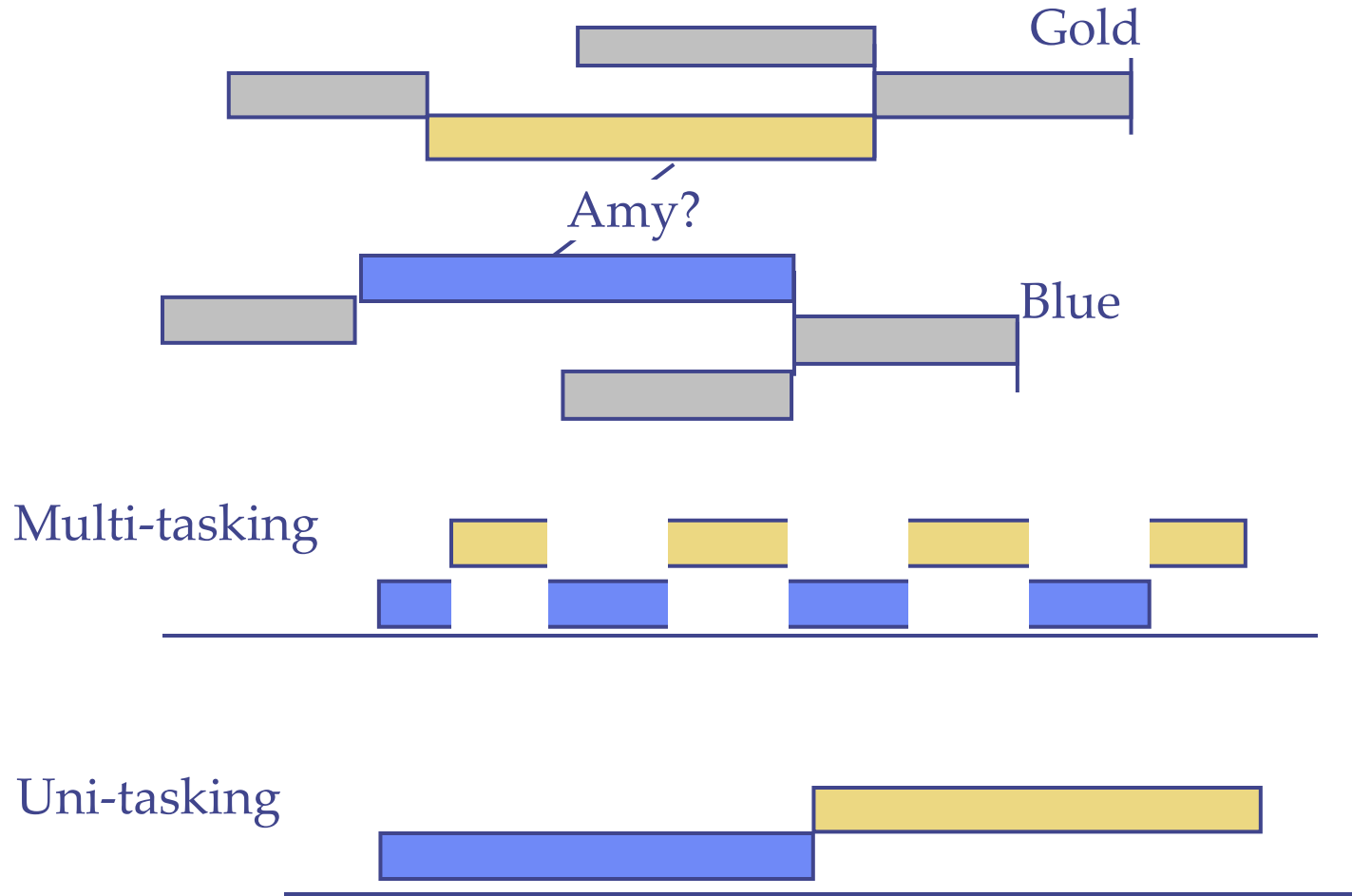

Pitfalls

- ◆ Buffer addiction
 - Plan responsibly
- ◆ Squandering buffers
 - Resist unmerited work
- ◆ Old management habits
 - New performance model
 - Respect for buffers

Questions & Discussion

John Farnbach

john@silverstreakpartners.com

Silver Streak Partners LLC

www.silverstreakpartners.com

Blog: <http://silverstreakpartners.com/BetterNPD/>

Silver Streak Partners LLC

© 2009 all rights reserved